

Anti-vib Tooling System

阻尼減振工具系統

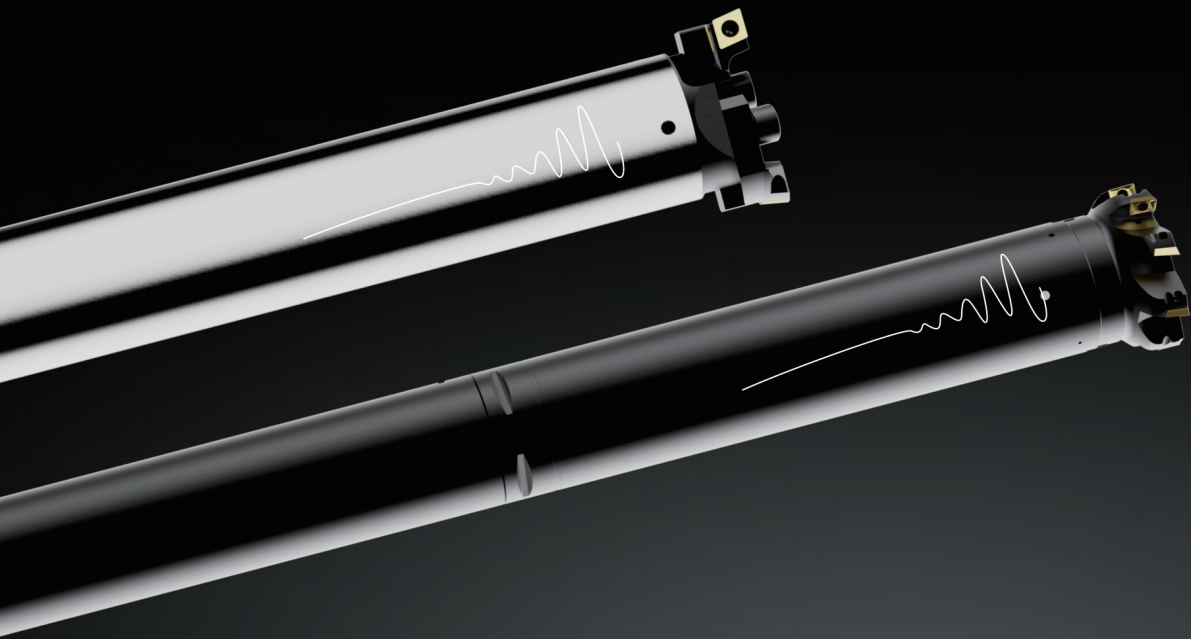

森泰英格（成都）数控刀具股份有限公司

CENTECH-EG CO.,LTD.

Anti-vib Tooling System

阻尼减振工具系统

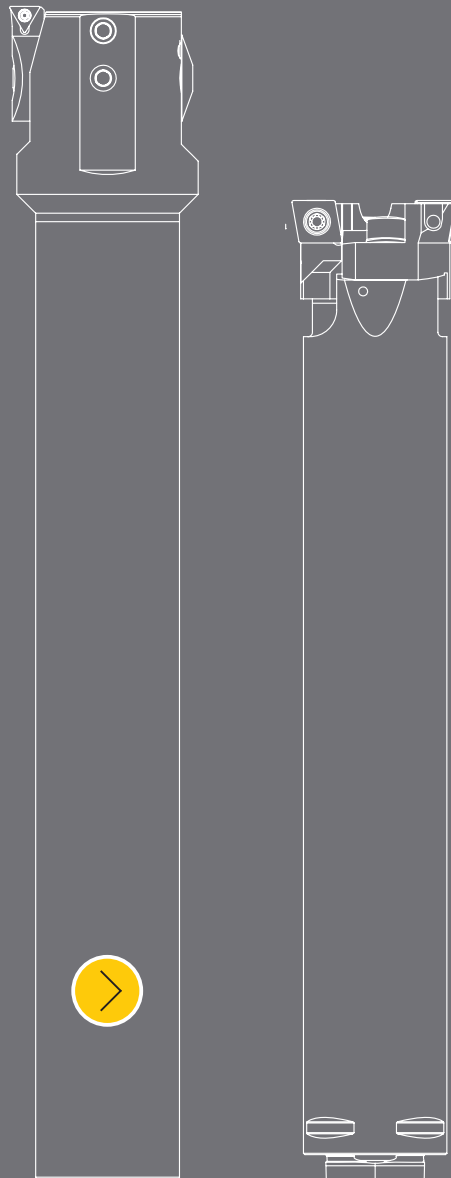

目录 Contents



阻尼减振工具系统 Anti-vib Tooling System

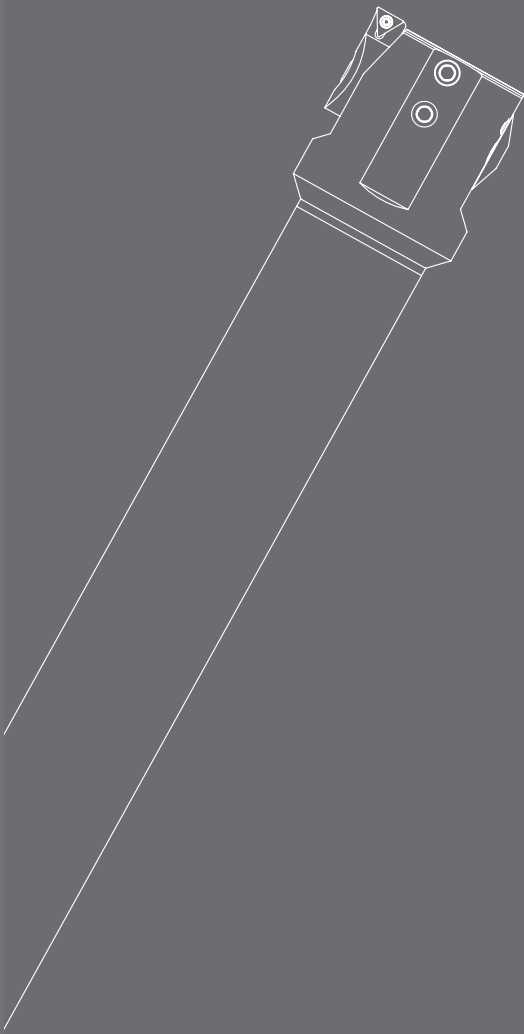

阻尼减振车刀 Anti-vib Turning Toolholders

阻尼减振车刀·····	A6
Anti-vib Turning Toolholders	
车刀头·····	A13
Turning Tool Heads	

阻尼减振镗刀 Anti-vib Boring Toolholders

阻尼减振镗刀·····	A24
Anti-vib Boring Toolholders	

阻尼减振铣刀 Anti-vibration Milling Toolholders

阻尼减振铣刀·····	A34
Anti-vibration Milling Toolholders	

Anti-vib Turning Toolholder

阻尼减振车刀

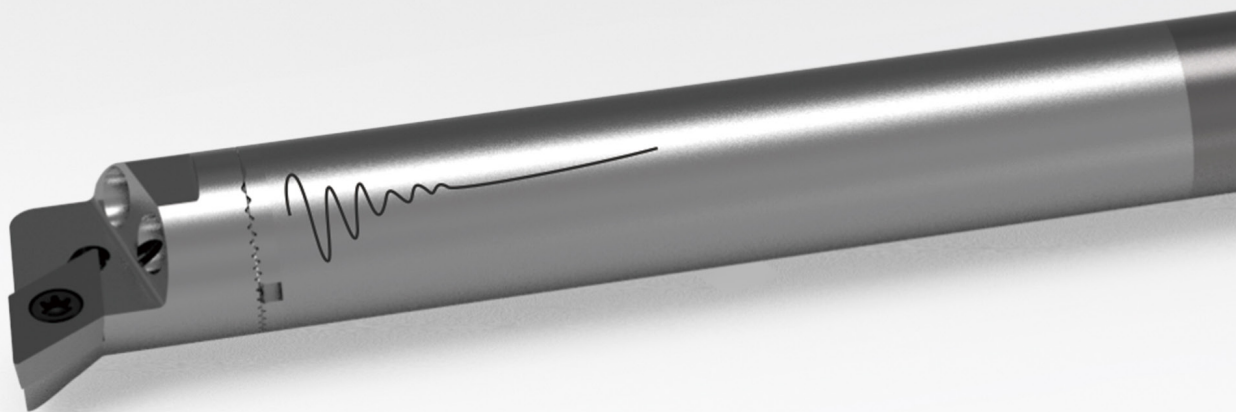

加工案例

Machining Examples

实例 Example

阻尼减振车刀

Anti-vibration Turning Toolholder

阻尼减振车刀特点

Characteristics of the Anti-vibration Turning Toolholder

- 有效降低车削振动，提高加工效率。
- 实加工表面质量高，提高刀具寿命，提效降本。
- Effectively reduces turning vibration and improves machining efficiency.
- High surface quality of the machined workpiece, extends tool life, and reduces costs while increasing efficiency.

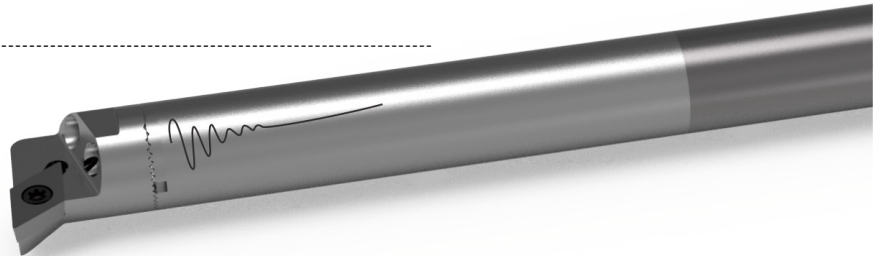

阻尼减振车刀加工案例

Anti-vibration Turning Toolholder Machining Case

加工部位：差速器壳体端面轴孔。

加工工序：内孔精车

加工精度：为保证两端内孔同心度，采用一次装夹实现两端内孔一次车削加工方案，阻尼减振车刀的使用完美解决了深孔加工振动的问题，实现两端内孔同心度 0.01mm，全跳动 0.08mm，表面粗糙度达到 Ra1.6 μ m。

Machined Area: Differential housing end face shaft hole

Machining Process: Internal hole precision turning

Machining Accuracy: To ensure concentricity of the internal holes at both ends, a solution involving single clamping for simultaneous turning of both internal holes was employed. The use of the damping and vibration-reducing carriage tool perfectly resolved the vibration issues associated with deep hole machining, achieving a concentricity of 0.01 mm at both ends, total runout of 0.08 mm, and a surface roughness of Ra 1.6 μ m.

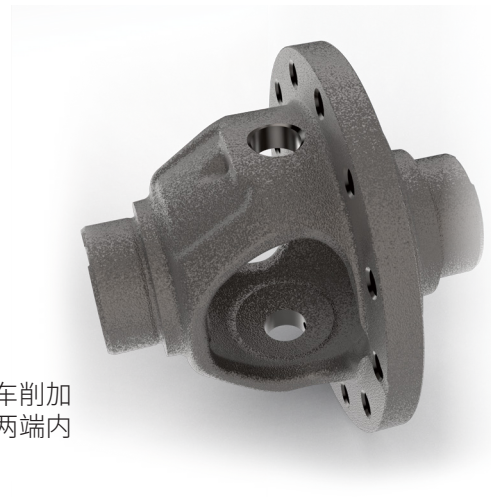

阻尼减振车刀

Anti-vib Turning Toolholder



- 中心通水, 冷却液压力 ≤ 70bar
 - Internal coolant supply, coolant pressure ≤ 70 bar

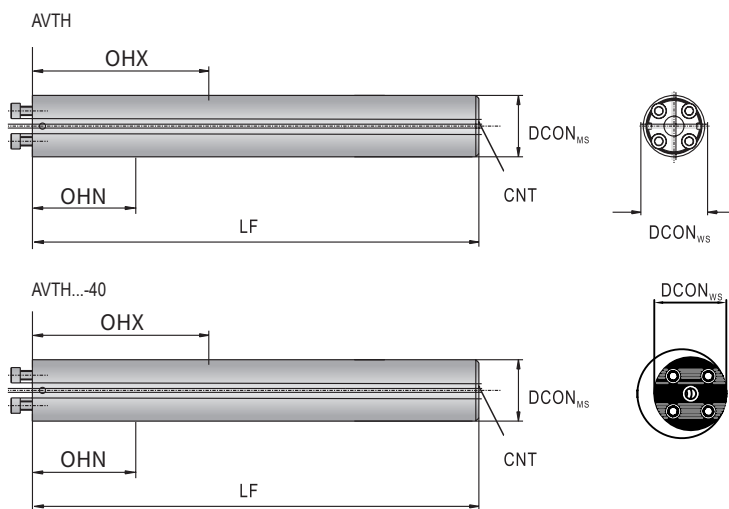

型号 Model	库存 Stock	尺寸 Dimension/mm						重量 Weight/kg
		DCON _{MS}	DCON _{WS}	LF	OHN	OHX	CNT	
AVTH-16-156	●	16.0	16.0	156	55	92	G1/8	0.2
AVTH-20-200	●	20.0	20.0	200	70	120	G1/4	0.4
AVTH-25-255	●	25.0	25.0	255	88	158	G1/4	0.9
AVTH-25-330	●	25.0	25.0	330	155	230	G1/4	1.2
AVTH-32-320	●	32.0	32.0	320	100	192	G3/8	2.0
AVTH-32-416	●	32.0	32.0	416	192	288	G3/8	2.6
AVTH-40-408	●	40.0	40.0	408	128	248	G1/2	3.5
AVTH-40-528	●	40.0	40.0	528	248	368	G1/2	5.1
AVTH-50-518-40	●	50.0	40.0	518	168	318	G1/2	7.3
AVTH-50-668-40	●	50.0	40.0	668	318	468	G1/2	9.3
AVTH-50-510	○	50.0	50.0	510	165	310	G1/2	7.2
AVTH-50-660	○	50.0	50.0	660	310	460	G1/2	9.1
AVTH-60-628-40	●	60.0	40.0	628	208	388	G3/4	12.7
AVTH-60-808-40	●	60.0	40.0	808	388	568	G3/4	16.5
AVTH-60-620	○	60.0	60.0	620	200	380	G3/4	12.6
AVTH-60-800	○	60.0	60.0	800	380	560	G3/4	16.2

●标准库存 ○订单生产

阻尼减振车刀

Anti-Vib Turning Toolholder



- 中心通水, 冷却液压力 ≤ 70bar
 - Internal coolant supply, coolant pressure ≤ 70 bar

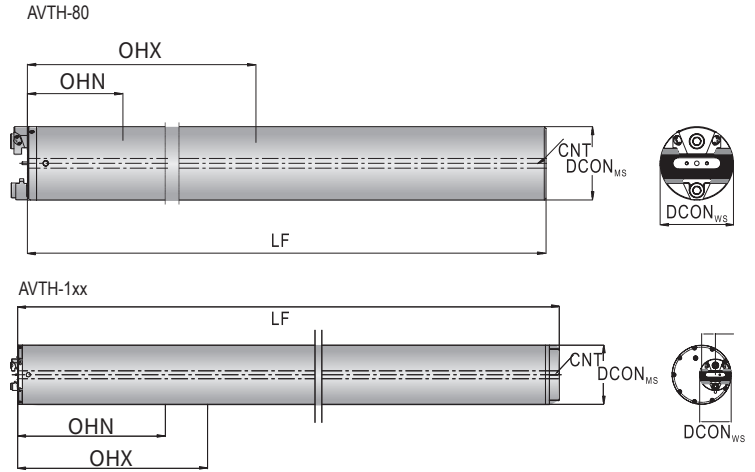

型号 Model	库存 Stock	尺寸 Dimension/mm						重量 Weight/kg
		DCON _{MS}	DCON _{WS}	LF	OHN	OHX	CNT	
AVTH-80-880	○	80	80	880	360	515	G3/4	31.3
AVTH-80-1200	○	80	80	1200	360	755	G3/4	43.4
AVTH-100-1100	○	100	80	1100	415	655	G3/4	63.1
AVTH-100-1500	○	100	80	1500	415	955	G3/4	86.6
AVTH-120-1900R	○	120	80	1900	795	1155	G3/4	133.7
AVTH-130-2000R	○	130	80	2000	865	1255	G3/4	192.0
AVTH-140-2200R	○	140	80	2200	935	1355	G3/4	241.0
AVTH-150-2400R	○	150	80	2400	1005	1455	G3/4	252.4
AVTH-160-2600R	○	160	80	2600	1075	1555	G3/4	339.0
AVTH-180-2800R	○	180	80	2800	1215	1755	G3/4	474.0
AVTH-200-3200R	○	200	80	3200	1355	1955	G1	546.0
AVTH-220-3450R	○	220	80	3450	1495	2155	G1	603.9
AVTH-250-4000R	○	250	80	4000	1705	2455	G1	980.1

●标准库存 ○订单生产

阻尼减振车刀

Anti-Vib Turning Toolholder



- 中心通水, 冷却液压力 ≤ 70bar
 - Internal coolant supply, coolant pressure ≤ 70 bar

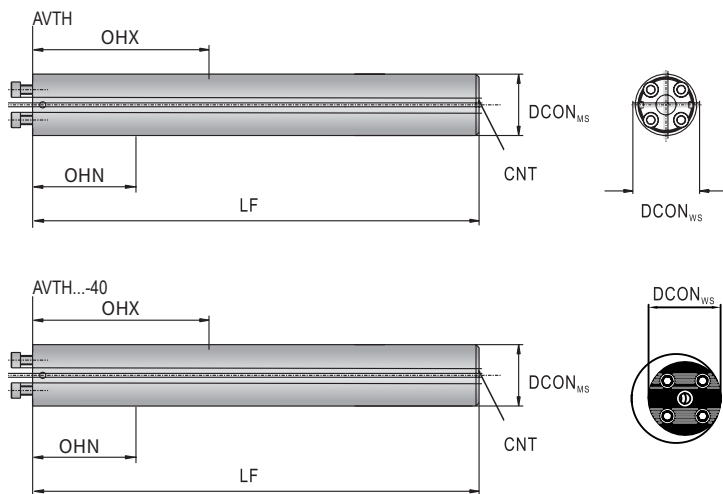

型号 Model	库存 Stock	尺寸 Dimension/mm						重量 Weight/kg
		DCON _{MS}	DCON _{WS}	LF	OHN	OHX	CNT	
AVTH-16-204CR	●	16	16	204	96	140	-	0.4
AVTH-20-260CR	●	20	20	260	120	180	-	0.8
AVTH-25-380CR	●	25	25	380	230	280	G1/8	6.3
AVTH-25-430CR	●	25	25	430	280	330	G1/8	6.4
AVTH-32-480CR	●	32	32	480	288	352	G1/4	10.2
AVTH-32-544CR	●	32	32	544	352	416	G1/4	10.7
AVTH-40-608CR	●	40	40	608	368	448	G3/8	15.0
AVTH-40-688CR	●	40	40	688	448	528	G3/8	16.5
AVTH-50-760CR-40	●	50	40	760	468	568	G1/2	25.5
AVTH-50-861CR-40	●	50	40	861	568	668	G1/2	27.0
AVTH-60-920CR-40	●	60	40	920	588	688	G3/4	25.8
AVTH-60-1040CR-40	●	60	40	1040	688	808	G3/4	28.0

● 标准库存 ○ 订单生产

阻尼减振车刀

Anti-vib Turning Toolholder

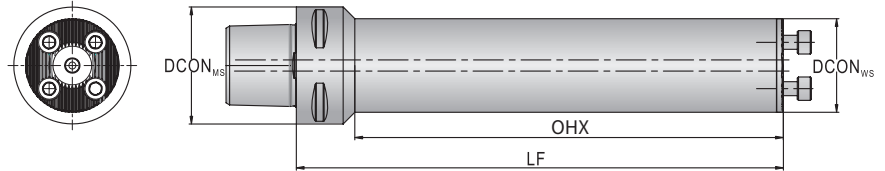

型号 Model	库存 Stock	尺寸 Dimension/mm				重量 Weight/kg
		DCON _{MS}	DCON _{WS}	LF	OHX	
PSC3-AVTH-16-82	○	32	16	82	63	0.25
PSC3-AVTH-20-101	○	32	20	101	82	0.39
PSC3-AVTH-25-125	○	32	25	125	107	0.6
PSC3-AVTH-25-180	○	32	25	180	161	0.8
PSC3-AVTH-32-133	○	32	32	133	133	1.0
PSC3-AVTH-32-224	○	32	32	224	224	1.8
PSC4-AVTH-16-88	○	40	16	88	63	0.4
PSC4-AVTH-20-107	○	40	20	107	82	0.54
PSC4-AVTH-25-132	○	40	25	132	108	0.8
PSC4-AVTH-25-180	○	40	25	180	155	0.96
PSC4-AVTH-32-154	○	40	32	154	131	1.29
PSC4-AVTH-32-224	○	40	32	224	200	2.1
PSC4-AVTH-40-173	○	40	40	173	173	1.75
PSC4-AVTH-40-288	○	40	40	288	288	3.42
PSC5-AVTH-16-85	○	50	16	85	58	0.64
PSC5-AVTH-20-109	○	50	20	109	83	0.74
PSC5-AVTH-25-133	○	50	25	133	107	1.0
PSC5-AVTH-25-180	○	50	25	180	154	1.2
PSC5-AVTH-25-230	○	50	25	230	200	1.4
PSC5-AVTH-32-154	○	50	32	154	129	1.4
PSC5-AVTH-32-224	○	50	32	224	199	1.88
PSC5-AVTH-32-288	○	50	32	288	261	2.4
PSC5-AVTH-40-194	○	50	40	194	170	2.24
PSC5-AVTH-40-288	○	50	40	288	263	3.62
PSC5-AVTH-40-368	○	50	40	368	344	4.2
PSC5-AVTH-50-215	○	50	50	215	215	5.47

●标准库存 ○订单生产

阻尼减振车刀

Anti-vib Turning Toolholder

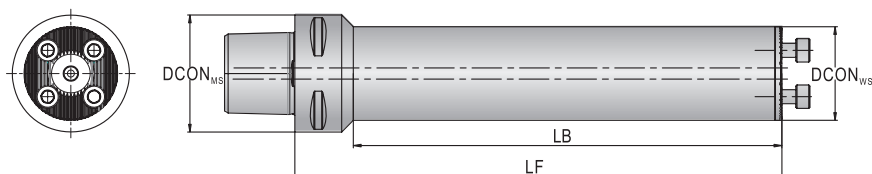

型号 Model	库存 Stock	尺寸 Dimension/mm				重量 Weight/kg
		DCON _{MS}	DCON _{WS}	LF	OHX	
PSC6-AVTH-16-88	○	63	16	88	58	1
PSC6-AVTH-20-108	○	63	20	108	78	1
PSC6-AVTH-25-132	○	63	25	132	103	1.36
PSC6-AVTH-25-180	○	63	25	180	146	1.7
PSC6-AVTH-25-230	○	63	25	230	197	1.8
PSC6-AVTH-32-159	○	63	32	159	129	1.8
PSC6-AVTH-32-224	○	63	32	224	191	2.2
PSC6-AVTH-32-288	○	63	32	288	257	2.7
PSC6-AVTH-40-198	○	63	40	198	169	2.6
PSC6-AVTH-40-288	○	63	40	288	257	4
PSC6-AVTH-40-368	○	63	40	368	338	4.2
PSC6-AVTH-50-239	○	63	50	239	212	6.3
PSC6-AVTH-60-287	○	63	60	287	263	9.2
PSC8-AVTH-25-147	○	80	25	147	107	2.3
PSC8-AVTH-32-172	○	80	32	172	133	2.8
PSC8-AVTH-32-224	○	80	32	224	184	3.62
PSC8-AVTH-40-224	○	80	40	224	186	3.7
PSC8-AVTH-40-288	○	80	40	288	246	5.25
PSC8-AVTH-40-368	○	80	40	368	330	5.4

●标准库存 ○订单生产

阻尼减振车刀

Anti-vib Turning Toolholder

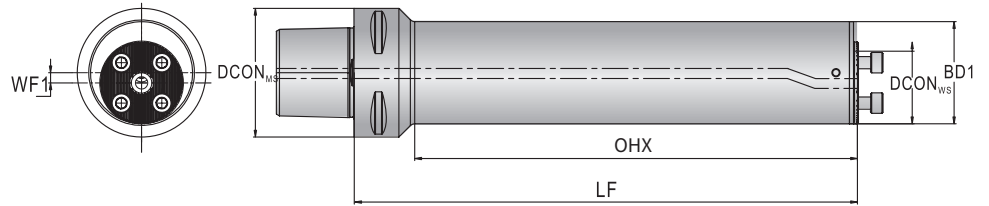

型号 Model		库存 Stock	尺寸 Dimension/mm				重量 Weight/kg	
右刀 Right hand	左刀 Left hand		DCON _{MS}	DCON _{WS}	LF	OHX		WF1
PSC5-AVTH-50-223-40R	PSC5-AVTH-50-223-40L	○	50	40	223	223	5	3.6
PSC5-AVTH-50-368-40R	PSC5-AVTH-50-368-40L	○	50	40	368	368	5	6.0
PSC5-AVTH-50-468-40R	PSC5-AVTH-50-468-40L	○	50	40	468	468	5	10.8
PSC6-AVTH-50-247-40R	PSC6-AVTH-50-247-40L	○	63	40	247	222	5	4.2
PSC6-AVTH-50-368-40R	PSC6-AVTH-50-368-40L	○	63	40	368	341	5	7.4
PSC6-AVTH-50-468-40R	PSC6-AVTH-50-468-40L	○	63	40	468	440	5	8.5
PSC6-AVTH-60-295-40R	PSC6-AVTH-60-295-40L	○	63	40	295	273	10	6.8
PSC6-AVTH-60-448-40R	PSC6-AVTH-60-448-40L	○	63	40	448	424	10	12.2
PSC6-AVTH-60-568-40R	PSC6-AVTH-60-568-40L	○	63	40	568	545	10	14.4
PSC8-AVTH-50-297-40R	PSC8-AVTH-50-297-40L	○	80	40	297	261	5	5.8
PSC8-AVTH-50-368-40R	PSC8-AVTH-50-368-40L	○	80	40	368	330	5	7.5
PSC8-AVTH-50-468-40R	PSC8-AVTH-50-468-40L	○	80	40	468	434	5	8.3
PSC8-AVTH-60-355-40R	PSC8-AVTH-60-355-40L	○	80	40	355	320	10	8.9
PSC8-AVTH-60-448-40R	PSC8-AVTH-60-448-40L	○	80	40	448	409	10	13
PSC8-AVTH-60-568-40R	PSC8-AVTH-60-568-40L	○	80	40	568	531	10	15.2

●标准库存 ○订单生产

阻尼减振车刀

Anti-vib Turning Toolholder

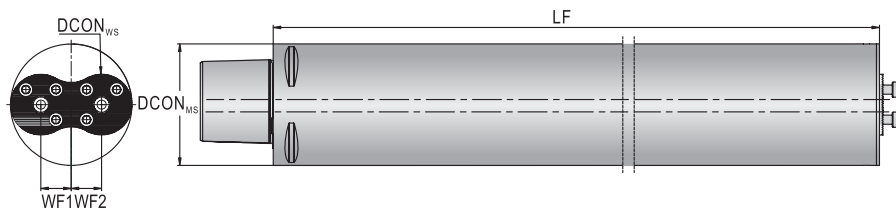

型号 Model	库存 Stock	尺寸 Dimension/mm						重量 Weight/kg
		DCON _{MS}	DCON _{WS}	LF	OHX	WF1	WF2	
PSC8-AVTH-80-365-40-2	○	80	40	365	365	20	20	13
PSC8-AVTH-80-608-40-2	○	80	40	608	608	20	20	28
PSC8-AVTH-80-768-40-2	○	80	40	768	768	20	20	28
PSC10-AVTH-80-768-40-2	○	100	40	768	729	20	20	29.5
PSC10-AVTH-100-968-40-2	○	100	40	968	968	30	30	58

●标准库存 ○订单生产

车刀头 Turning Tool Head

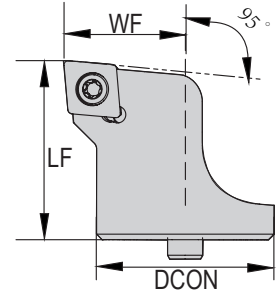

右手刀图例 Right hand style shown

型号 Model		库存 Stock		尺寸 Dimension/mm					重量 Weight/kg	刀片 Insert
右刀 Right hand	左刀 Left hand	R	L	DCON	LF	WF	THCA	LPR		
AVTH-SCLCR-16-06	AVTH-SCLCL-16-06	●	●	16	20	11	-	-	0.03	CCMT0602..
AVTH-SCLCR-20-09	AVTH-SCLCL-20-09	●	●	20	20	13	-	-	0.05	CCMT09T3..
AVTH-SCLCR-25-09HP	AVTH-SCLCL-25-09HP	●	●	25	20	17	-	-	0.07	CCMT09T3..
AVTH-SCLCR-32-09HP	AVTH-SCLCL-32-09HP	●	●	32	32	22	-	-	0.13	CCMT09T3..
AVTH-SCLCR-40-12HP	AVTH-SCLCL-40-12HP	●	●	40	38	27	-	-	0.24	CCMT1204..

*刀片单独订购。

* Inserts ordered separately.

●标准库存 ○订单生产

车刀头 Turning Tool Head

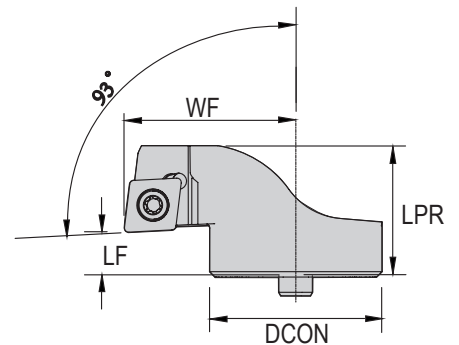

右手刀图例 Right hand style shown

型号 Model	库存 Stock	尺寸 Dimension/mm					重量 Weight/kg	刀片 Insert
		DCON	LF	WF	THCA	LPR		
AVTH-SCUCR-16-09-16X	●	16	7	24	-	22	0.05	CCMT09T3..
AVTH-SCUCR-20-09-20X	●	20	7	30	-	22	0.07	CCMT09T3..
AVTH-SCUCR-25-09-18X	●	25	7	30.5	-	24	0.09	CCMT09T3..
AVTH-SCUCR-32-09-16X	●	32	8	32	-	24	0.12	CCMT09T3..
AVTH-SCUCR-40-09-18X	●	40	8	38	-	24	0.18	CCMT09T3..
AVTH-SCUCR-40-09-26X	●	40	8	46	-	24	0.21	CCMT09T3..

*刀片单独订购。

* Inserts ordered separately.

●标准库存 ○订单生产

车刀头

Turning Tool Head

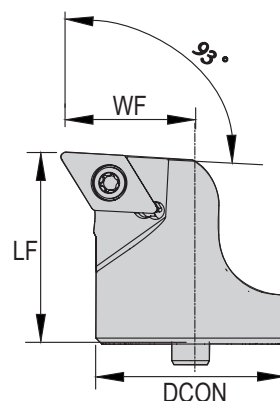

右手刀图例 Right hand style shown

右刀 Right hand	型号 Model	左刀 Left hand	库存 Stock		尺寸 Dimension/mm					重量 Weight/kg	刀片 Insert
			R	L	DCON	LF	WF	THCA	LPR		
AVTH-SDUCR-16-07		AVTH-SDUCL-16-07	●	●	16	20	11	-	-	0.03	DCMT0702..
AVTH-SDUCR-20-11		AVTH-SDUCL-20-11	●	●	20	20	13	-	-	0.05	DCMT11T3..
AVTH-SDUCR-25-11HP		AVTH-SDUCL-25-11HP	●	●	25	23	17	-	-	0.08	DCMT11T3..
AVTH-SDUCR-32-11HP		AVTH-SDUCL-32-11HP	●	●	32	32	22	-	-	0.14	DCMT11T3..
AVTH-SDUCR-40-11HP		AVTH-SDUCL-40-11HP	●	●	40	32	27	-	-	0.21	DCMT11T3..

*刀片单独订购。

* Inserts ordered separately.

●标准库存 ○订单生产

车刀头

Turning Tool Head

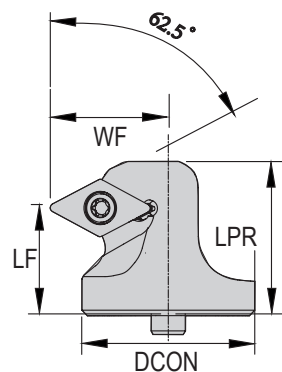
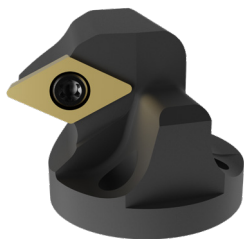

右手刀图例 Right hand style shown

右刀 Right hand	型号 Model	左刀 Left hand	库存 Stock		尺寸 Dimension/mm					重量 Weight/kg	刀片 Insert
			R	L	DCON	LF	WF	THCA	LPR		
AVTH-SDXCR-16-07-E		AVTH-SDXCL-16-07-E	●	●	16	15	13	-	18.8	0.03	DCMT0702..
AVTH-SDXCR-20-07-E		AVTH-SDXCL-20-07-E	●	●	20	15	15	-	18.8	0.04	DCMT0702..
AVTH-SDXCR-25-07-DHP		AVTH-SDXCL-25-07-DHP	●	●	25	15	18	-	19.7	0.07	DCMT0702..
AVTH-SDXCR-32-11HP		AVTH-SDXCL-32-11HP	●	●	32	20	22	-	28	0.12	DCMT11T3..
AVTH-SDXCR-40-11HP		AVTH-SDXCL-40-11HP	●	●	40	20	27	-	28	0.19	DCMT11T3..

*刀片单独订购。

* Inserts ordered separately.

●标准库存 ○订单生产

车刀头

Turning Tool Head

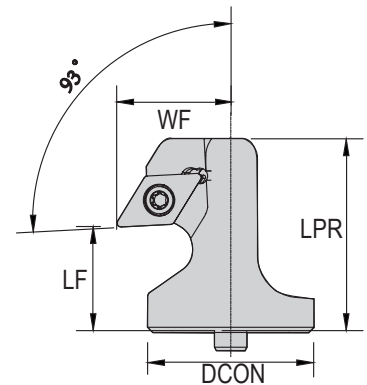

右手刀图例 Right hand style shown

型号 Model		库存 Stock		尺寸 Dimension/mm					重量 Weight/kg	刀片 Insert
R	L	R	L	DCON	LF	WF	THCA	LPR		
AVTH-SDUCR-16-07-EX	AVTH-SDUCL-16-07-EX	●	●	16	15	13	-	26.6	0.03	DCMT0702..
AVTH-SDUCR-20-07-EX	AVTH-SDUCL-20-07-EX	●	●	20	15	15	-	26.6	0.05	DCMT0702..
AVTH-SDUCR-25-07-DXHP	AVTH-SDUCL-25-07-DXHP	●	●	25	15	18	-	27.9	0.09	DCMT0702..
AVTH-SDUCR-32-11XHP	AVTH-SDUCL-32-11XHP	●	●	32	20	22	-	37	0.15	DCMT11T3..
AVTH-SDUCR-40-11XHP	AVTH-SDUCL-40-11XHP	●	●	40	20	27	-	37	0.5	DCMT11T3..

*刀片单独订购。

* Inserts ordered separately.

●标准库存 ○订单生产

车刀头

Turning Tool Head

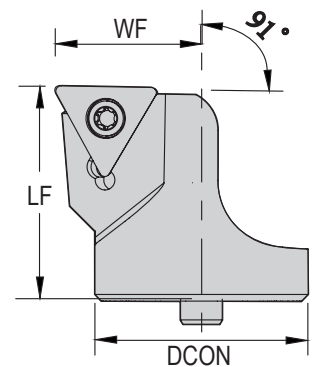
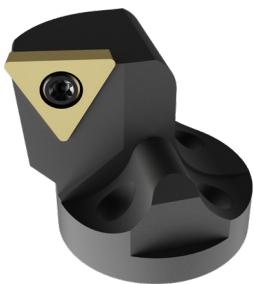

右手刀图例 Right hand style shown

型号 Model		库存 Stock		尺寸 Dimension/mm					重量 Weight/kg	刀片 Insert
右刀 Right hand	左刀 Left hand	R	L	DCON	LF	WF	THCA	LPR		
AVTH-STFCR-16-09	AVTH-STFCL-16-09	●	●	16	20	11	-	-	0.03	TCMT0902..
AVTH-STFCR-16-11-B1	AVTH-STFCL-16-11-B1	●	●	16	20	11	-	-	0.03	TCMT1102..
AVTH-STFCR-20-11-B1	AVTH-STFCL-20-11-B1	●	●	20	20	13	-	-	0.04	TCMT1102..
AVTH-STFCR-25-11-B1HP	AVTH-STFCL-25-11-B1HP	●	●	25	20	17	-	-	0.07	TCMT1102..
AVTH-STFCR-32-16HP	AVTH-STFCL-32-16HP	●	●	32	32	22	-	-	0.14	TCMT16T3..
AVTH-STFCR-40-16HP	AVTH-STFCL-40-16HP	●	●	40	32	27	-	-	0.22	TCMT16T3..

*刀片单独订购。

* Inserts ordered separately.

●标准库存 ○订单生产

车刀头

Turning Tool Head

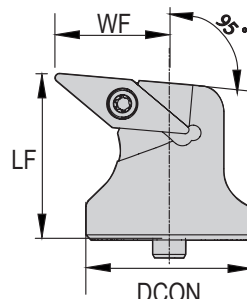
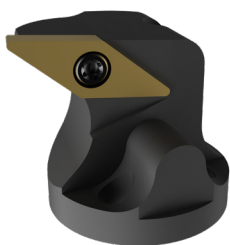

右手刀图例 Right hand style shown

右刀 Right hand	型号 Model	左刀 Left hand	库存 Stock		尺寸 Dimension/mm					重量 Weight/kg	刀片 Insert
			R	L	DCON	LF	WF	THCA	LPR		
AVTH-SVLBR-25-16-LFHP		AVTH-SVLBL-25-16-LFHP	●	●	25	25	20	-	-	0.08	VBMT1604..
AVTH-SVLBR-32-16HP		AVTH-SVLBL-32-16HP	●	●	32	32	22	-	-	0.13	VBMT1604..
AVTH-SVPBR-32-16-LHP		AVTH-SVPBL-32-16-LHP	●	●	32	34	22	-	-	0.12	VBMT1604..
AVTH-SVLBR-40-16HP		AVTH-SVLBL-40-16HP	●	●	40	32	27	-	-	0.19	VBMT1604..
AVTH-SVPBR-40-16-LHP		AVTH-SVPBL-40-16-LHP	●	●	40	34	27	-	-	0.17	VBMT1604..

*刀片单独订购。

* Inserts ordered separately.

●标准库存 ○订单生产

车刀头

Turning Tool Head

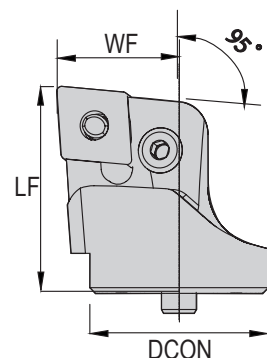
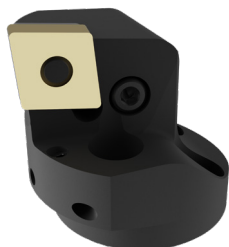

右手刀图例 Right hand style shown

右刀 Right hand	型号 Model	左刀 Left hand	库存 Stock		尺寸 Dimension/mm					重量 Weight/kg	刀片 Insert
			R	L	DCON	LF	WF	THCA	LPR		
AVTH-PCLNR-25-09HP-G		AVTH-PCLNL-25-09HP-G	●	●	25	28	19	-	-	0.08	CNMG0903..
AVTH-PCLNR-32-12HP		AVTH-PCLNL-32-12HP	●	●	32	36	22	-	-	0.16	CNMG1204..
AVTH-PCLNR-40-12HP		AVTH-PCLNL-40-12HP	●	●	40	35	27	-	-	0.21	CNMG1204..
AVTH-PCLNR-40-16HP		AVTH-PCLNL-40-16HP	●	●	40	42	27	-	-	0.27	CNMG1606..

*刀片单独订购。

* Inserts ordered separately.

●标准库存 ○订单生产

车刀头

Turning Tool Head

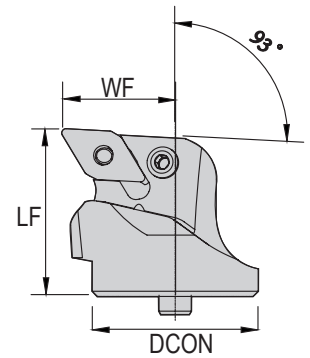

右手刀图例 Right hand style shown

右刀 Right hand	型号 Model	左刀 Left hand	库存 Stock		尺寸 Dimension/mm					重量 Weight/kg	刀片 Insert
			R	L	DCON	LF	WF	THCA	LPR		
AVTH-PDUNR-25-11HP-G		AVTH-PDUNL-25-11HP-G	●	●	25	32	21	-	-	0.1	DNMG1104..
AVTH-PDUNR-32-11HP		AVTH-PDUNL-32-11HP	●	●	32	32	22	-	-	0.13	DNMG1104..
AVTH-PDUNR-40-15HP		AVTH-PDUNL-40-15HP	●	●	40	36	30	-	-	0.24	DNMG1506..

*刀片单独订购。

* Inserts ordered separately.

●标准库存 ○订单生产

车刀头

Turning Tool Head

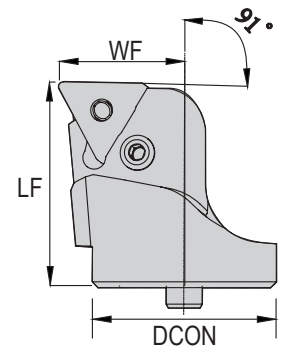
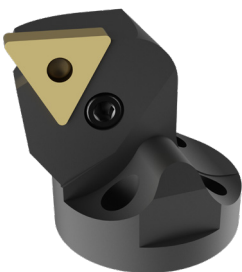

右手刀图例 Right hand style shown

右刀 Right hand	型号 Model	左刀 Left hand	库存 Stock		尺寸 Dimension/mm					重量 Weight/kg	刀片 Insert
			R	L	DCON	LF	WF	THCA	LPR		
AVTH-PTFNR-32-16HP		AVTH-PTFNL-32-16HP	●	●	32	35	22	-	-	0.16	TNMG1604..
AVTH-PTFNR-40-16HP		AVTH-PTFNL-40-16HP	●	●	40	35	27	-	-	0.23	TNMG1604..

*刀片单独订购。

* Inserts ordered separately.

●标准库存 ○订单生产

车刀头

Turning Tool Head

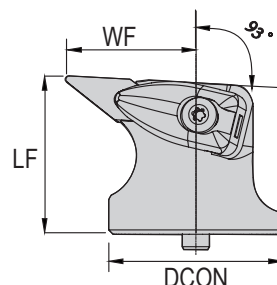

右手刀图例 Right hand style shown

型号 Model		库存 Stock		尺寸 Dimension/mm					重量 Weight/kg	刀片 Insert
右刀 Right hand	左刀 Left hand	R	L	DCON	LF	WF	THCA	LPR		
AVTH-DVUNR-40-16	AVTH-DVUNL-40-16	●	●	40	36	30	-	-	0.24	VNMG1604..

*刀片单独订购。

* Inserts ordered separately.

●标准库存 ○订单生产

车刀头

Turning Tool Head

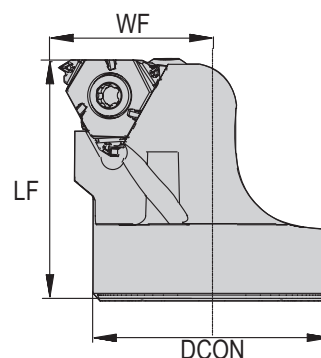
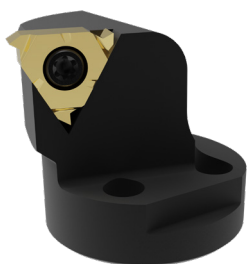

右手刀图例 Right hand style shown

型号 Model		库存 Stock		尺寸 Dimension/mm					重量 Weight/kg	刀片 Insert
右刀 Right hand	左刀 Left hand	R	L	DCON	LF	WF	THCA	LPR		
AVTH-SNR-202514-16	AVTH-SNL-202514-16	●	●	20	25	14	1°	-	0.06	16NR/L..
AVTH-SNR-252517-16	AVTH-SNL-252517-16	●	●	25	25	17	1°	-	0.08	16NR/L..
AVTH-SNR-323222-16	AVTH-SNL-323222-16	●	●	32	32	22	1°	-	0.16	16NR/L..
AVTH-SNR-403227-16	AVTH-SNL-403227-16	●	●	40	32	27	1°	-	0.22	16NR/L..
AVTH-SNR-252819-22	AVTH-SNL-252819-22	●	●	25	28	19	1°	-	0.09	22NR/L..
AVTH-SNR-323222-22	AVTH-SNL-323222-22	●	●	32	32	21.9	1°	-	0.13	22NR/L..
AVTH-SNR-403227-22	AVTH-SNL-403227-22	●	●	40	32	26.9	1°	-	0.2	22NR/L..
AVTH-SNR-403627-27	AVTH-SNL-403627-27	●	●	40	36	26.9	1°	-	0.23	27NR/L..

*刀片单独订购。

* Inserts ordered separately.

●标准库存 ○订单生产

车刀头

Turning Tool Head

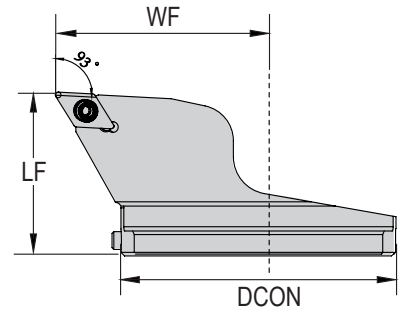

右手刀图例 Right hand style shown

右刀 Right hand	型号 Model	左刀 Left hand	库存 Stock		尺寸 Dimension/mm					重量 Weight/kg	刀片 Insert
			R	L	DCON	LF	WF	THCA	LPR		
AVTH-SDUCR-80-11		AVTH-SDUCL-80-11	●	●	80	45.7	57	-	-	0.55	DCMT11T308

*刀片单独订购。

* Inserts ordered separately.

●标准库存 ○订单生产

车刀头

Turning Tool Head

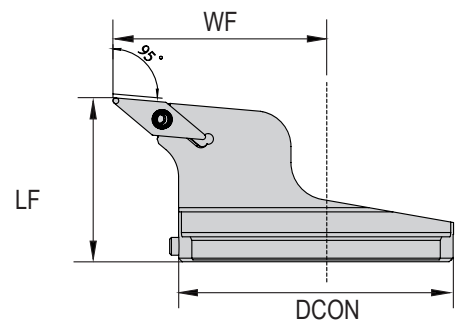
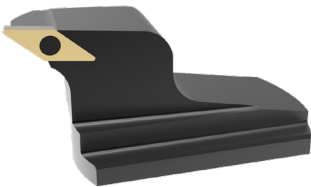

右手刀图例 Right hand style shown

右刀 Right hand	型号 Model	左刀 Left hand	库存 Stock		尺寸 Dimension/mm					重量 Weight/kg	刀片 Insert
			R	L	DCON	LF	WF	THCA	LPR		
AVTH-SVLBR-80-16		AVTH-SVLBL-80-16	●	●	80	45.7	57	-	-	0.49	VBMT 16 04 08

*刀片单独订购。

* Inserts ordered separately.

●标准库存 ○订单生产

车刀头

Turning Tool Head

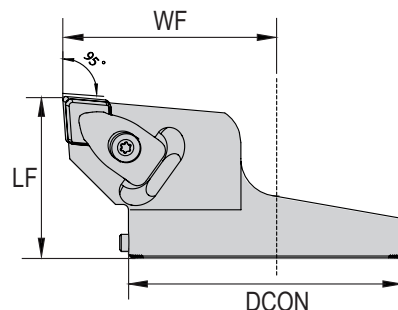
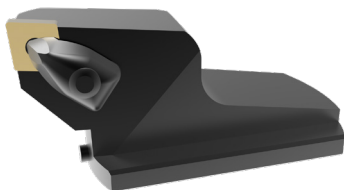

右手刀图例 Right hand style shown

型号 Model		库存 Stock		尺寸 Dimension/mm					重量 Weight/kg	刀片 Insert
右刀 Right hand	左刀 Left hand	R	L	DCON	LF	WF	THCA	LPR		
AVTH-DCLNR-80-12	AVTH-DCLNL-80-12	●	●	80	45	57	-	-	0.56	CNMG120408
AVTH-DCLNR-80-16	AVTH-DCLNL-80-16	●	●	80	45	57	-	-	0.6	CNMG160612

*刀片单独订购。

* Inserts ordered separately.

●标准库存 ○订单生产

车刀头

Turning Tool Head

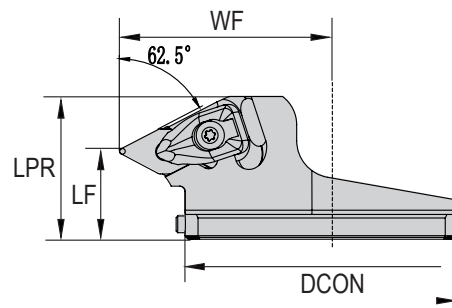
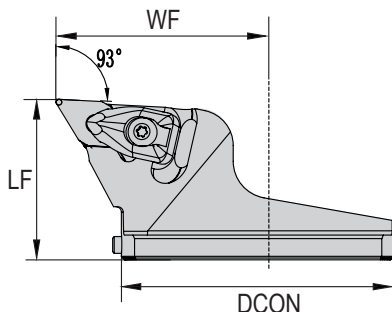
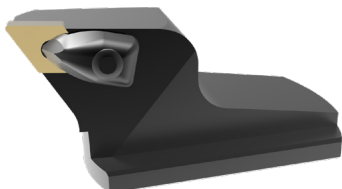

右手刀图例 Right hand style shown

型号 Model		库存 Stock		尺寸 Dimension/mm					重量 Weight/kg	刀片 Insert
右刀 Right hand	左刀 Left hand	R	L	DCON	LF	WF	THCA	LPR		
AVTH-DDUNR-80-15	AVTH-DDUNL-80-15	●	●	80	45	57	-	-	0.56	DNMG150608
AVTH-DDXNR-80-15	AVTH-DDXNL-80-15	●	●	80	25	57	-	40.3	0.5	DNMG150608

*刀片单独订购。

* Inserts ordered separately.

●标准库存 ○订单生产

车刀头

Turning Tool Head

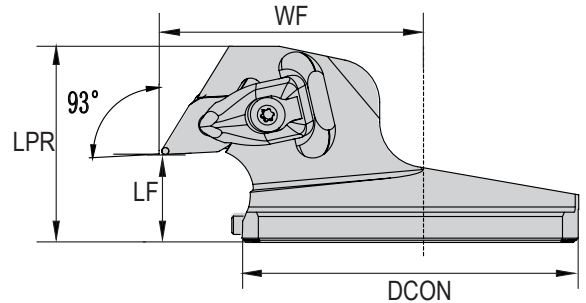
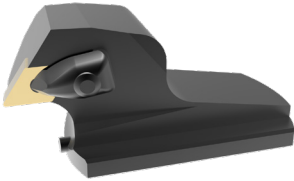

右手刀图例 Right hand style shown

型号 Model		库存 Stock		尺寸 Dimension/mm					重量 Weight/kg	刀片 Insert
右刀 Right hand	左刀 Left hand	R	L	DCON	LF	WF	THCA	LPR		
AVTH-DDUNR-80-15X	AVTH-DDUNL-80-15X	●	●	80	20	57	-	45	0.55	DNMG150608

*刀片单独订购。

* Inserts ordered separately.

●标准库存 ○订单生产

车刀头

Turning Tool Head

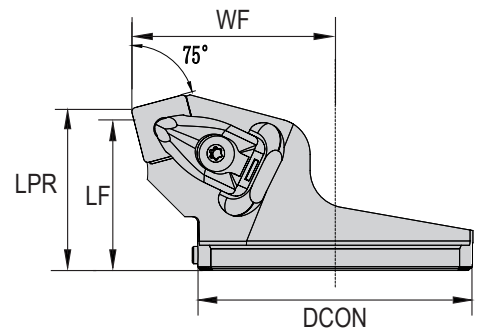
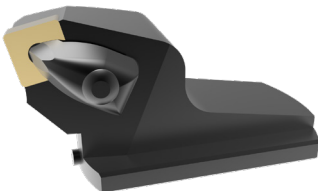

右手刀图例 Right hand style shown

型号 Model		库存 Stock		尺寸 Dimension/mm					重量 Weight/kg	刀片 Insert
右刀 Right hand	左刀 Left hand	R	L	DCON	LF	WF	THCA	LPR		
AVTH-DSKNR-80-15	AVTH-DSKNL-80-15	●	●	80	45	57	-	48.1	0.6	SNMG150612

*刀片单独订购。

* Inserts ordered separately.

●标准库存 ○订单生产

车刀头

Turning Tool Head

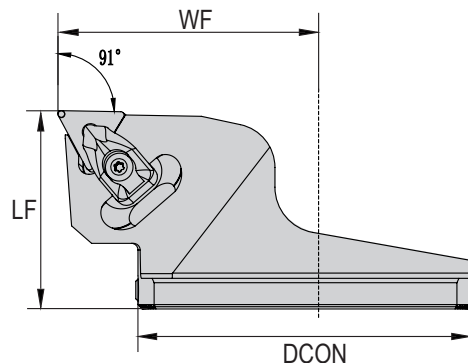
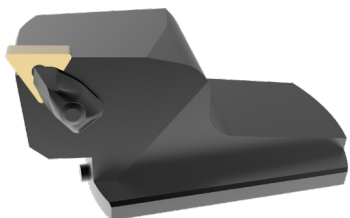

右手刀图例 Right hand style shown

右刀 Right hand	型号 Model	左刀 Left hand	库存 Stock		尺寸 Dimension/mm					重量 Weight/kg	刀片 Insert
			R	L	DCON	LF	WF	THCA	LPR		
AVTH-DTFNR-80-16		AVTH-DTFNL-80-16	●	●	80	45	57	-	-	0.6	TNMG 16 04 08

*刀片单独订购。

* Inserts ordered separately.

●标准库存 ○订单生产

车刀头

Turning Tool Head

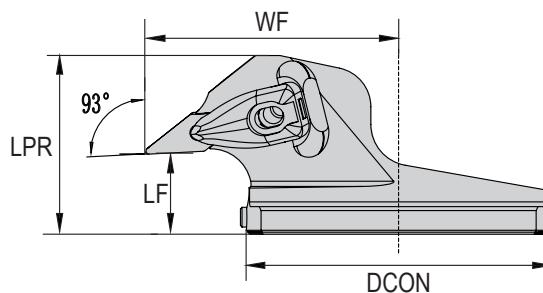
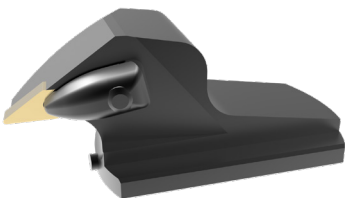

右手刀图例 Right hand style shown

右刀 Right hand	型号 Model	左刀 Left hand	库存 Stock		尺寸 Dimension/mm					重量 Weight/kg	刀片 Insert
			R	L	DCON	LF	WF	THCA	LPR		
AVTH-DVUNR-80-16X		AVTH-DVUNL-80-16X	●	●	80	20	64	-	45	0.55	VNMG160408

*刀片单独订购。

* Inserts ordered separately.

●标准库存 ○订单生产

Anti-vib Boring Toolholder

阻尼減振鏜刀

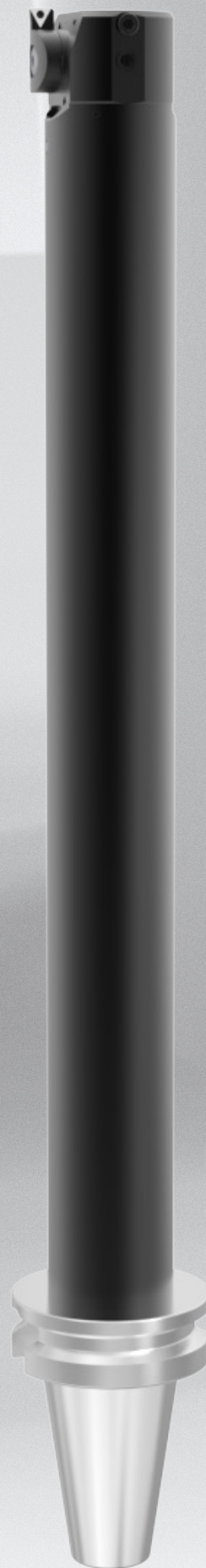
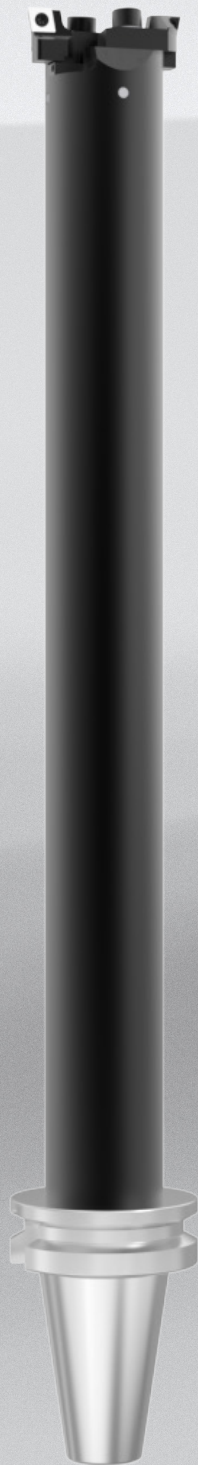

阻尼减振镗刀

Anti-vib Boring Toolholder

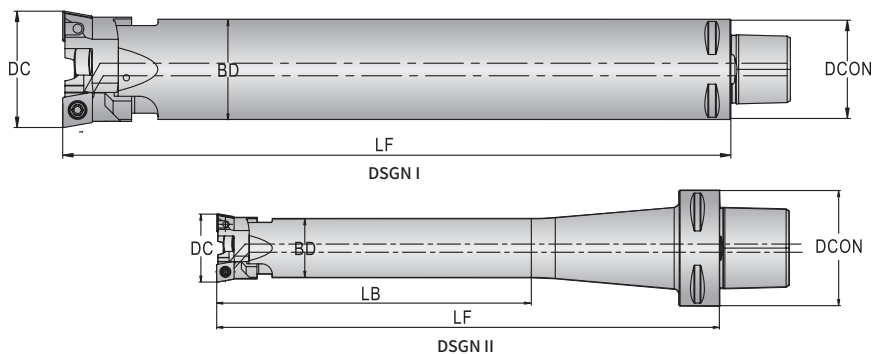

型号 Model	库存 Stock	DC		尺寸 Dimension/mm				镗头型号 Boringhead		刀片 Insert	重量 Weight/kg	DSGN
		DCN	DCX	DCON	LF	LB	BD					
PSC3-AVBH-D32d20-199.TCR023	●	23	29	32	199	138	20	KD23-90.CC06-A	KD23-90.CC06-B	CCMT060204	1.283	II
PSC3-AVBH-D32d25-216.TCR028	●	28	36	32	216	166	25	KD28-90.CC06-A	KD28-90.CC06-B	CCMT060204	1.73	II
PSC3-AVBH-D32d25-216.TTR028	○	28	36	32	216	166	25	KD28-90.TC09-A	KD28-90.TC09-B	TCMT090204	1.718	II
PSC3-AVBH-32-221.TCR035	●	35	45	32	221		32	KD35-90.CC09-A	KD35-90.CC09-B	CCMT09T308	2.007	I
PSC4-AVBH-D40d32-270.TCR035	●	35	45	40	270	210	32	KD35-90.CC09-A	KD35-90.CC09-B	CCMT09T308	4.313	II
PSC6-AVBH-D63d32-297.TCR035	○	35	45	63	297	210	32	KD35-90.CC09-A	KD35-90.CC09-B	CCMT09T308	4.945	II
PSC3-AVBH-32-221.TTR035	○	35	45	32	221		32	KD35-90.TC11-A	KD35-90.TC11-B	TCMT110304	2.33	I
PSC4-AVBH-D40d32-270.TTR035	○	35	45	40	270	210	32	KD35-90.TC11-A	KD35-90.TC11-B	TCMT110304	4.217	II
PSC4-AVBH-40-220.TCR044	●	44	56	40	220		40	KD44-90.CC09-A	KD44-90.CC09-B	CCMT09T308	2.925	I
PSC5-AVBH-D50d40-336.TCR044	●	44	56	50	336	264	40	KD44-90.CC09-A	KD44-90.CC09-B	CCMT09T308	3.72	II
PSC6-AVBH-D63d40-363.TCR044	○	44	56	63	363	264	40	KD44-90.CC09-A	KD44-90.CC09-B	CCMT09T308	7.021	II
PSC4-AVBH-40-220.TTR044	○	44	56	40	220		40	KD44-90.TC11-A	KD44-90.TC11-B	TCMT110304	2.4	I
PSC5-AVBH-D50d40-336.TTR044	○	44	56	50	363	264	40	KD44-90.TC11-A	KD44-90.TC11-B	TCMT110304	6.049	II

●标准库存 ○订单生产

阻尼减振镗刀

Anti-vib Boring Toolholder

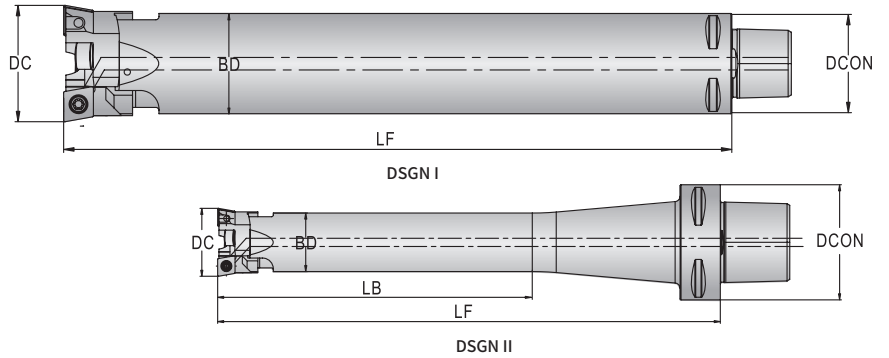

型号 Model	库存 Stock	DC		尺寸 Dimension/mm				镗头型号 Boringhead	刀片 Insert	重量 Weight/kg	DSGN	
		DCN	DCX	DCON	LF	LB	BD					
PSC5-AVBH-50-300.TCR055	●	55	71	50	300	-	50	KD55-90.CC12-A	KD55-90.CC12-B	CCMT120408	7.7	I
PSC6-AVBH-D63d50-400.TCR055	●	55	71	63	400	330	50	KD55-90.CC12-A	KD55-90.CC12-B	CCMT120408	6.94	II
PSC5-AVBH-50-300.TTR055	○	55	71	50	300	-	50	KD55-90.TC16-A	KD55-90.TC16-B	TCMT16T308	5	I
PSC6-AVBH-63-400.TCR070	●	70	90	63	400	-	63	KD70-90.CC12-A	KD70-90.CC12-B	CCMT120408	9.91	I
PSC8-AVBH-D80d63-500.TCR070	○	70	90	80	500	420	63	KD70-90.CC12-A	KD70-90.CC12-B	CCMT120408	12.66	II
PSC6-AVBH-63-400.TTR070	○	70	90	63	400	-	63	KD55-90.TC16-A	KD55-90.TC16-B	TCMT16T308	9.93	I
PSC8-AVBH-80-500.TCR089	●	89	116	80	500	-	80	KD89-90.CC12-A	KD89-90.CC12-B	CCMT120408	18.49	I
PSC8-AVBH-80-410.TCR089	●	89	116	80	410	-	80	KD89-90.CC12-A	KD89-90.CC12-B	CCMT120408	16.14	I
PSC8-AVBH-80-500.TTR089	○	89	116	80	500	-	80	KD89-90.TC16-A	KD89-90.TC16-B	TCMT16T308	22.08	I
PSC8-AVBH-80-410.TTR089	○	89	116	80	410	-	80	KD89-90.TC16-A	KD89-90.TC16-B	TCMT16T308	16.16	I
PSC8-AVBH-80-500.TCR115	●	115	150	80	500	-	80	KD115-90.CC12-A	KD115-90.CC12-B	CCMT120408	18.62	I
PSC8-AVBH-80-500.TTR115	○	115	150	80	500	-	80	KD89-90.TC16-A	KD89-90.TC16-B	TCMT16T308	23.2	I

●标准库存 ○订单生产

阻尼减振镗刀 (10D)

Anti-vib Boring Toolholder

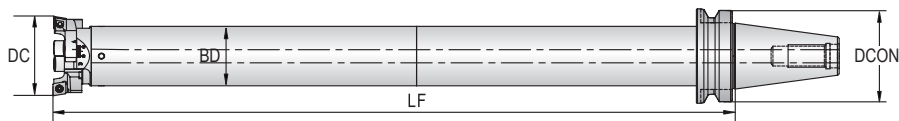

型号 Model	库存 Stock	DC		尺寸 Dimension/mm				镗头型号 Boringhead		刀片 Insert	重量 Weight/kg
		DCN	DCX	DCON	LF	LB	BD				
BT50-AVBH-20-240CR.TCR023	●	23	29	100	240	202	20	KD23-90.CC06-A	KD23-90.CC06-B	CCMT060204	4.5
BT50-AVBH-25-290CR.TCR028	●	28	36	100	290	252	25	KD28-90.CC06-A	KD28-90.CC06-B	CCMT060204	5
BT50-AVBH-32-360CR.TCR035	●	35	45	100	360	322	32	KD35-90.CC09-A	KD35-90.CC09-B	CCMT09T308	6.3
BT50-AVBH-40-440CR.TCR044	●	44	56	100	440	402	40	KD44-90.CC09-A	KD44-90.CC09-B	CCMT09T308	9
BT50-AVBH-50-540CR.TCR055	●	55	71	100	540	502	50	KD55-90.CC12-A	KD55-90.CC12-B	CCMT120408	12.7
BT50-AVBH-63-670CR.TCR070	●	70	90	100	670	632	63	KD70-90.CC12-A	KD70-90.CC12-B	CCMT120408	23.2
BT50-AVBH-80-840CR.TCR089	●	89	116	100	840	802	80	KD89-90.CC12-A	KD89-90.CC12-B	CCMT120408	41.2
BT50-AVBH-80-840CR.TCR115	●	115	150	100	840	802	80	KD115-90.CC12-A	KD115-90.CC12-B	CCMT120408	41.2

●标准库存 ○订单生产

阻尼减振镗刀

Anti-vib Boring Toolholder

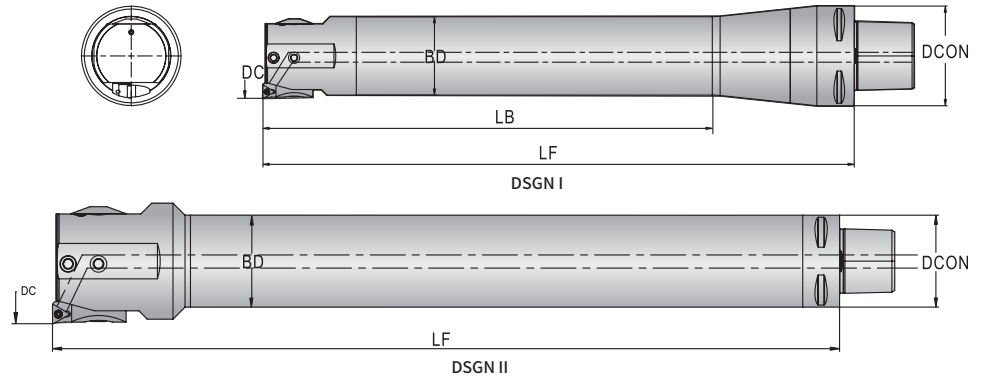

型号 Model	库存 Stock	DC		尺寸 Dimension/mm				适配刀座 Cartridge	刀片 Insert	主偏角 Lead angle	重量 Weight/kg	DSGN
		DCN	DCX	DCON	LF	LB	BD					
PSC4-AVBH-D40d18-163.FBZ019	○	19	23	40	163	114	18	FAH1-1	TP..080204	90°	0.57	I
PSC4-AVBH-D40d20-199.FBZ023	●	23	29	40	199	138	20	FAHA-1	TP..080204	90°	0.73	I
PSC3-AVBH-D32d25-216.FBZ028	●	28	36	32	216	168	25	BZ021.TP08	TP..080204	90°	0.97	I
PSC3-AVBH-32-221.FBZ035	●	35	45	32	221	-	32	BZ031.TP08	TP..080204	90°	2.22	II
PSC4-AVBH-D40d32-270.FBZ035	○	35	45	40	270	210	32	BZ031.TP08	TP..080204	90°	1.92	I
PSC6-AVBH-D63d32-297.FBZ035	○	35	45	63	297	210	32	BZ031.TP08	TP..080204	90°	2.57	I
PSC4-AVBH-40-220.FBZ044	●	44	56	40	220	-	40	BZ041.TC11	TC..110204	90°	2.22	II
PSC5-AVBH-D50d40-336.FBZ044	●	44	56	50	336	264	40	BZ041.TC11	TC..110204	90°	1.92	I
PSC6-AVBH-D63d40-363.FBZ044	○	44	56	63	363	264	40	BZ041.TC11	TC..110204	90°	2.57	I
PSC5-AVBH-50-300.FBZ055	●	55	70	50	300	-	50	BZ051.TC11	TC..110204	90°	4.94	II
PSC6-AVBH-D63d50-400.FBZ055	○	55	70	63	400	330	50	BZ051.TC11	TC..110204	90°	6.78	I
PSC6-AVBH-63-400.FBZ069	●	69	87	63	400	-	63	BZ061.TC11	TC..110204	90°	9.71	II
PSC8-AVBH-D80d63-500.FBZ069	○	69	87	80	500	414	63	BZ061.TC11	TC..110204	90°	12.87	I
PSC6-AVBH-63-400.FBZ086	●	86	107	63	400	-	63	BZ06X.TC11	TC..110204	90°	9.72	II
PSC8-AVBH-80-500.FBZ086	●	86	107	80	400	-	80	BZ06X.TC11	TC..110204	90°	18.00	II
PSC8-AVBH-80-410.FBZ086	●	86	107	80	410	-	80	BZ06X.TC11	TC..110204	90°	15.55	II
PSC6-AVBH-63-400.FBZ106	●	106	137	63	400	-	63	BZ061.TC11	TC..110204	90°	9.80	II
PSC8-AVBH-80-500.FBZ106	○	106	137	80	500	-	80	BZ061.TC11	TC..110204	90°	18.20	II
PSC8-AVBH-80-410.FBZ106	○	106	137	80	410	-	80	BZ061.TC11	TC..110204	90°	15.75	II
PSC8-AVBH-80-500.FBZ136	●	136	167	80	500	-	80	BZ062.TC11	TC..110204	90°	18.36	II

●标准库存 ○订单生产

阻尼减振镗刀 (10D) Anti-vib Boring Toolholder(10D)

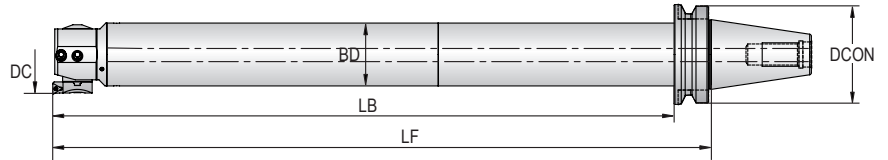

型号 Model	库存 Stock	DC		尺寸 Dimension/mm				适配刀座 Cartridge	刀片 Insert	主偏角 Lead angle	重量 Weight/kg
		DCN	DCX	DCON	LF	LB	BD				
BT50-AVBH-20-250CR.FBZ023	●	23	29	100	250	202	20	FAH1-1	TP..080204	90°	4.5
BT50-AVBH-25-290CR.FBZ028	●	28	36	100	290	252	25	BZ031.TP08	TP..080204		5
BT50-AVBH-32-360CR.FBZ035	●	35	45	100	360	322	32	BZ031.TP08	TP..080204	90°	6.3
BT50-AVBH-40-440CR.FBZ044	●	44	56	100	440	402	40	BZ041.TC11	TC..110204		9
BT50-AVBH-50-540CR.FBZ055	●	55	70	100	540	502	50	BZ051.TC11	TC..110204	90°	12.7
BT50-AVBH-63-670CR.FBZ069	●	69	87	100	670	632	63	BZ061.TC11	TC..110204		23.2
BT50-AVBH-80-840CR.FBZ086	●	86	107	100	840	802	80	BZ06X.TC11	TC..110204	90°	41.2
BT50-AVBH-80-840CR.FBZ106	●	106	137	100	840	802	80	BZ061.TC11	TC..110204	90°	41.2
BT50-AVBH-80-840CR.FBZ136	●	136	167	100	840	802	80	BZ062.TC11	TC..110204	90°	41.2

●标准库存 ○订单生产

阻尼减振刀杆

Anti-vib Boring Toolholder

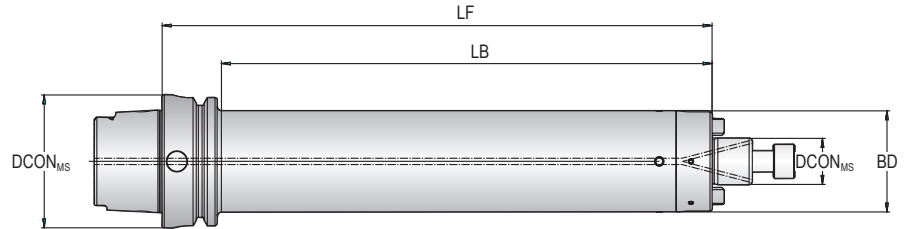

型号 Model	库存 Stock	尺寸 Dimension/mm					重量 Weight/kg
		DCON _{MS}	DCON _{WS}	LF	LB	BD	
HSK63A-AVMH-38-160-FMB16	○	63	16	160	131	38	4.35
HSK63A-AVMH-38-230-FMB16	○	63	16	230	201	38	5.06
HSK63A-AVMH-48-210-FMB22	○	63	22	210	181	48	6.1
HSK63A-AVMH-48-260-FMB22	○	63	22	260	231	48	6.89
HSK100A-AVMH-48-213-FMB22	○	100	22	213	181	48	7.68
HSK100A-AVMH-48-263-FMB22	○	100	22	263	231	48	8.55
HSK100A-AVMH-60-230-FMB22	○	100	22	230	198	60	9.78
HSK100A-AVMH-60-340-FMB22	○	100	22	340	308	60	12.96
HSK100A-AVMH-76-250-FMB27	○	100	27	250	218	76	14.13
HSK100A-AVMH-76-390-FMB27	○	100	27	390	358	76	20
HSK100A-AVMH-80-250-FMB32	○	100	32	250	218	80	15.3
HSK100A-AVMH-80-390-FMB32	○	100	32	390	358	80	21.07

●标准库存 ○订单生产

阻尼减振刀杆

Anti-vib Boring Toolholder

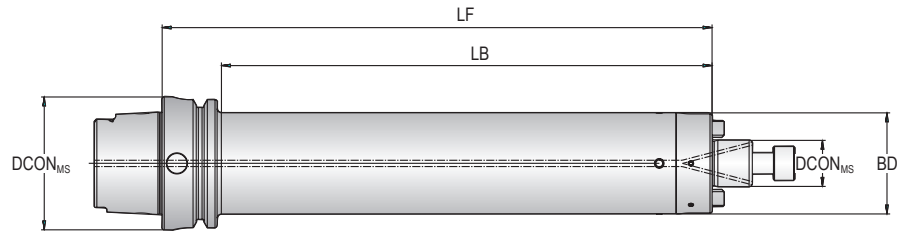

型号 Model	库存 Stock	尺寸 Dimension/mm					重量 Weight/kg
		DCON _{MS}	DCON _{WS}	LF	LB	BD	
HSK63A-AVMH-38-160-XMB16	○	63	16	160	131	38	4.35
HSK63A-AVMH-38-230-XMB16	○	63	16	230	201	38	5.06
HSK63A-AVMH-48-210-XMB22	○	63	22	210	181	48	6.1
HSK63A-AVMH-48-260-XMB22	○	63	22	260	231	48	6.89
HSK100A-AVMH-48-213-XMB22	○	100	22	213	181	48	7.68
HSK100A-AVMH-48-263-XMB22	○	100	22	263	231	48	8.55
HSK100A-AVMH-60-230-XMB22	○	100	22	230	198	60	9.78
HSK100A-AVMH-60-340-XMB22	○	100	22	340	308	60	12.96
HSK100A-AVMH-76-250-XMB27	○	100	27	250	218	76	14.13
HSK100A-AVMH-76-390-XMB27	○	100	27	390	358	76	20
HSK100A-AVMH-80-250-XMB32	○	100	32	250	218	80	15.3
HSK100A-AVMH-80-390-XMB32	○	100	32	390	358	80	21.07

* 本产品已升级成 FMB 阻尼减振刀杆, 待库存产品销售完毕后仅接受非标订货。

● 标准库存 ○ 订单生产

* The XMB model has been upgraded to the FMB, custom orders only after stock depletion.

Anti-vib Milling Toolholder

阻尼减振铣刀



Anti-vibration Tooling System

阻尼减振工具系统



减振工具系统随着科学技术的不断发展，零件也变得的复杂多样，给机加行业带来了一系列的难题，与此同时，也对数控切削刀具的多样性、可靠性、稳定性提出更高的要求。加工时的振刀情况，会导致工件表面质量差、尺寸精度超差，并且会引起刀具寿命急剧下降，甚至可能损坏机床主轴。

为此，森泰英格技术团队自主研发了阻尼减振工具系统，将着力解决深腔加工精度低、效率低、成本高的难题。

With the continuous development of technology, components have become increasingly complex and diverse, presenting a series of challenges to the machining industry. At the same time, there are higher demands for the diversity, reliability, and stability of CNC cutting tools. The Vibration during machining can lead to poor surface quality, dimensional accuracy deviations, and can cause a rapid decrease in tool life, potentially even damaging the machine tool spindle.

To address this, the technical team at ENGC has independently developed the anti-vibration tooling system, which aims to solve the problems of low precision, low efficiency, and high costs associated with deep cavity machining.

阻尼减振技术 Vibration Reduction Technology

通过在结构中添加机构或者阻尼材料，降低结构的振动幅度，使振动能量尽可能多的转变成热能等其他形式的能量耗散的方法，称为阻尼减振技术。

传统刀具在深腔加工时，由于长径比太大，容易发生刀杆的振动，影响加工精度和表面质量。减振工具系统带有减振机构，能够在长悬伸加工工况下，抑制切削时的振动，保持优秀的生产效率和精度，并可以延长刀具使用寿命，降低加工成本。

Vibration reduction technology refers to methods that involve adding mechanisms or damping materials to a structure to reduce its vibration amplitude. This approach aims to convert as much of the vibrational energy as possible into heat or other forms of energy dissipation.

Traditional tools can experience vibration in the tool shank during deep cavity machining due to their high length-to-diameter ratio, which negatively impacts machining precision and surface quality. The anti-vibration tooling system is equipped with a damping mechanism that can suppress vibrations during cutting in long overhang conditions, maintaining excellent production efficiency and precision. Additionally, it can extend tool life and reduce machining costs.

+ 加工案例 Machining Examples

■ 实例 Example

阻尼减振铣刀 Anti-vibration Milling Toolholder

阻尼减振铣刀特点 Characteristics of the Anti-vibration Milling Toolholder

- 长悬伸，有效降低铣削振动。
- 模块化接口设计，高刚性高精度机床接口。
- 提高整体切削效率，提高刀片寿命。
- Long overhang, effectively reduces milling vibration.
- Modular interface design, with high rigidity and high-precision machine tool interfaces.
- Enhances overall cutting efficiency and extends tool life.

阻尼减振铣刀加工案例 Anti-vibration Milling Toolholder Machining Case

加工部位：电机壳轴承孔。
加工特点：轴承孔粗加工 + 轴承孔端面精加工
加工难点：深孔内壁铣削加工，薄壁件铣削，大长径比双金属铣削，底部无空刀设计。
加工精度：垂直度 0.05mm、平面度 0.03mm、粗糙度 Ra1.6 μ m。

Machined Area: Motor housing bearing hole

Machining Characteristics: Rough machining of the bearing hole + Precision machining of the bearing hole end face

Machining Challenges: Deep hole inner wall milling, thin-walled part milling, large length-to-diameter ratio bimetallic milling, no air cutting design at the bottom.

Machining Accuracy: Verticality 0.05 mm, flatness 0.03 mm, roughness Ra 1.6 μ m.

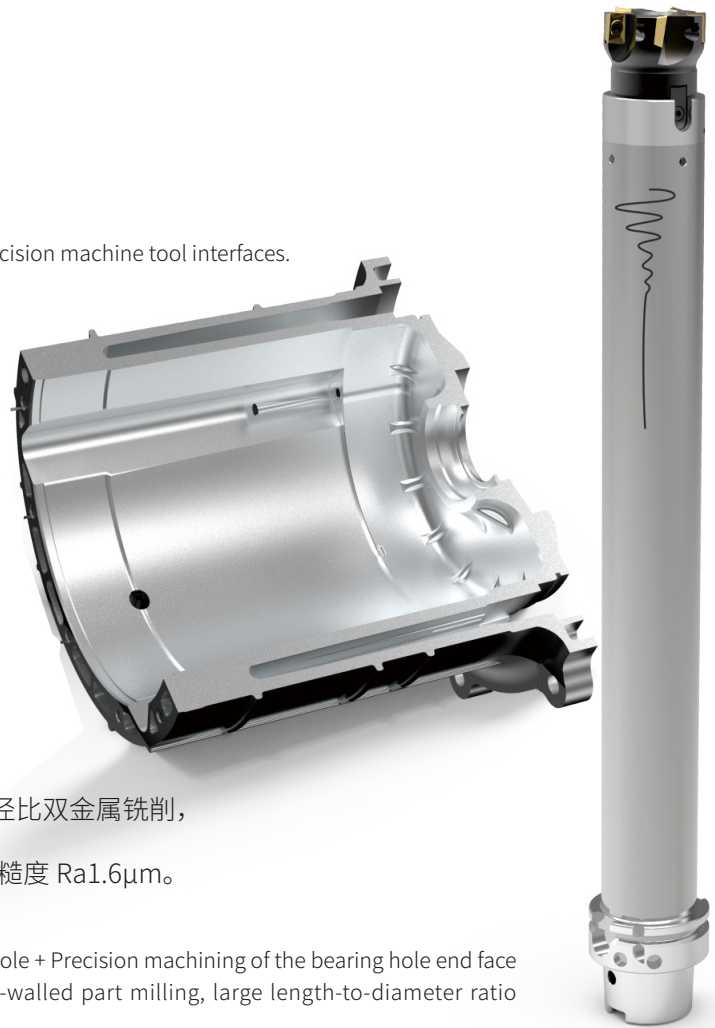

阻尼减振刀杆 Anti-vib Milling Toolholder

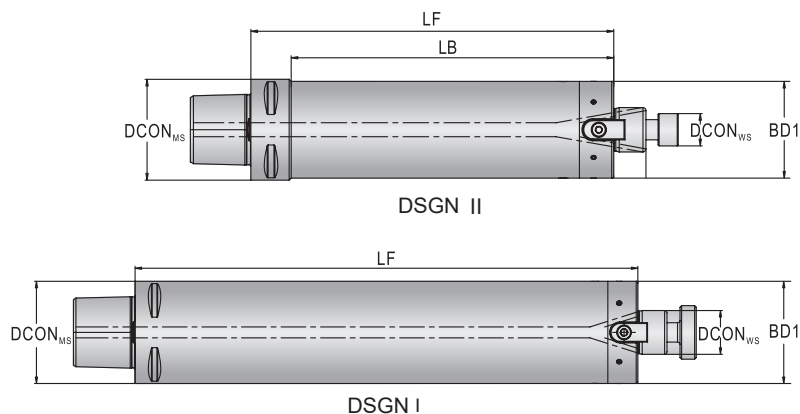

型号 Model	库存 Stock	尺寸 Dimension/mm					DSGN	重量 Weight/kg
		DCON _{MS}	DCON _{WS}	LF	LB	BD ₁		
PSC4-AVMH-38-130-FMB16	●	40	16	130	107.8	38	II	1.6
PSC4-AVMH-38-200-FMB16	●	40	16	200	177.8	38	II	2.3
PSC5-AVMH-48-180-FMB22	●	50	22	180	157.6	47.5	II	3.2
PSC5-AVMH-48-220-FMB22	●	50	22	220	197.6	47.5	II	6
PSC5-AVMH-48-270-FMB22	●	50	22	270	247.6	47.5	II	6.8
PSC6-AVMH-60-200-FMB22	○	63	22	200	175.4	60	II	8
PSC6-AVMH-60-260-FMB22	●	63	22	260	235.4	60	II	9.3
PSC6-AVMH-60-310-FMB22	●	63	22	310	285.4	63	II	10.9
PSC6-AVMH-63-200-FMB27	●	63	27	200	200	63	I	8.5
PSC6-AVMH-63-260-FMB27	●	63	27	260	260	63	I	9.9
PSC6-AVMH-63-310-FMB27	●	63	27	310	310	63	I	11.6
PSC8-AVMH-76-220-FMB27	●	80	27	220	187.2	76	II	13
PSC8-AVMH-76-320-FMB27	●	80	27	320	287.2	76	II	16.8
PSC8-AVMH-76-360-FMB27	●	80	27	360	327.2	76	II	18.2
PSC8-AVMH-80-220-FMB32	●	80	32	220	220	80	I	13.7
PSC8-AVMH-80-320-FMB32	●	80	32	320	320	80	I	18
PSC8-AVMH-80-360-FMB32	●	80	32	360	360	80	I	19.6
PSC10-AVMH-95-400-FMB32	○	100	32	400	361	95	II	30.5
PSC10-AVMH-100-400-FMB40	○	100	40	400	400	100	I	28.3

●标准库存 ○订单生产

阻尼减振刀杆

Anti-vib Milling Toolholder

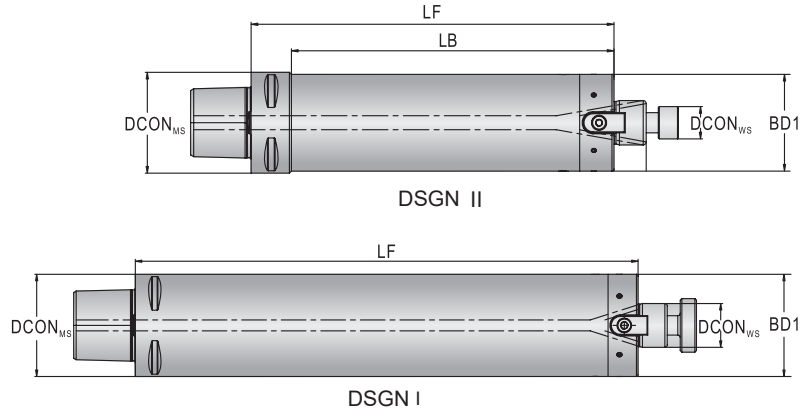

型号 Model	库存 Stock	尺寸 Dimension/mm					DSGN	重量 Weight/kg
		DCON _{MS}	DCON _{WS}	LF	LB	BD ₁		
PSC4-AVMH-38-130-XMB16	●	40	16	130	107.8	38	II	1.6
PSC4-AVMH-38-200-XMB16	●	40	16	200	177.8	38	II	2.3
PSC5-AVMH-48-180-XMB22	●	50	22	180	157.6	47.5	II	3.2
PSC5-AVMH-48-220-XMB22	●	50	22	220	197.6	47.5	II	6
PSC5-AVMH-48-270-XMB22	●	50	22	270	247.6	47.5	II	6.8
PSC6-AVMH-60-200-XMB22	○	63	22	200	175.4	60	II	8
PSC6-AVMH-60-260-XMB22	●	63	22	260	235.4	60	II	9.3
PSC6-AVMH-60-310-XMB22	●	63	22	310	285.4	63	II	10.9
PSC6-AVMH-63-200-XMB27	●	63	27	200	200	63	I	8.5
PSC6-AVMH-63-260-XMB27	●	63	27	260	260	63	I	9.9
PSC6-AVMH-63-310-XMB27	●	63	27	310	310	63	I	11.6
PSC8-AVMH-76-220-XMB27	●	80	27	220	187.2	76	II	13
PSC8-AVMH-76-320-XMB27	●	80	27	320	287.2	76	II	16.8
PSC8-AVMH-76-360-XMB27	●	80	27	360	327.2	76	II	18.2
PSC8-AVMH-80-220-XMB32	●	80	32	220	220	80	I	13.7
PSC8-AVMH-80-320-XMB32	●	80	32	320	320	80	I	18
PSC8-AVMH-80-360-XMB32	●	80	32	360	360	80	I	19.6
PSC10-AVMH-95-400-XMB32	○	100	32	400	361	95	II	30.5
PSC10-AVMH-100-400-XMB40	○	100	40	400	400	100	I	28.3

* 本产品已升级成FMB阻尼减振刀杆, 待库存产品销售完毕后仅接受非标订货。

●标准库存 ○订单生产

* The XMB model has been upgraded to the FMB, custom orders only after stock depletion.

SEGNC 森泰英格®